

QMP DUST COLLECTING SYSTEMS SERVICE MANUAL

Rev B – 02/25/2009

CONTENTS

GENERAL	Page 1
PICK-UP-POT	Page 2-3
CYCLONE/SEPARATOR	Page 4
DUST COLLECTOR CABINET	Page 5-10
A) Fan Motor	Page 5
B) Fan Wheels	Page 5
C) Filters	Page 6
D) Electronic Timer	Page 7
E) Pneumatics	Page 8
i. Filter Regulator	
ii. Manifold Drain	
iii. Impulse Valve	
iv. Solenoid	
F) Manometer	Page 9
G) Hoses	Page 9
TROUBLESHOOTING	Page 10
TECHNICAL DATA & SETTINGS	Page 11
WARRANTY	Page 12

GENERAL

Proper installation, operation, and maintenance are essential for the system to operate efficiently. Dust laden air enters the system at the Pick-Up-Pot, passes through suction hoses to the Cyclone/Separator where 65% to 90% of the dust will drop out. The remaining dust laden air will then pass through suction hoses to the Dust Collector cabinet. The air will be filtered and exhausted with the dust dropping out near the bottom of the unit. The filters are continually cleaned by forcing pulsed air through the filter elements causing dust to drop from the surface of the filter element. It is necessary to maintain each component of the system to maintain the superior performance we expect from a dust collection system.

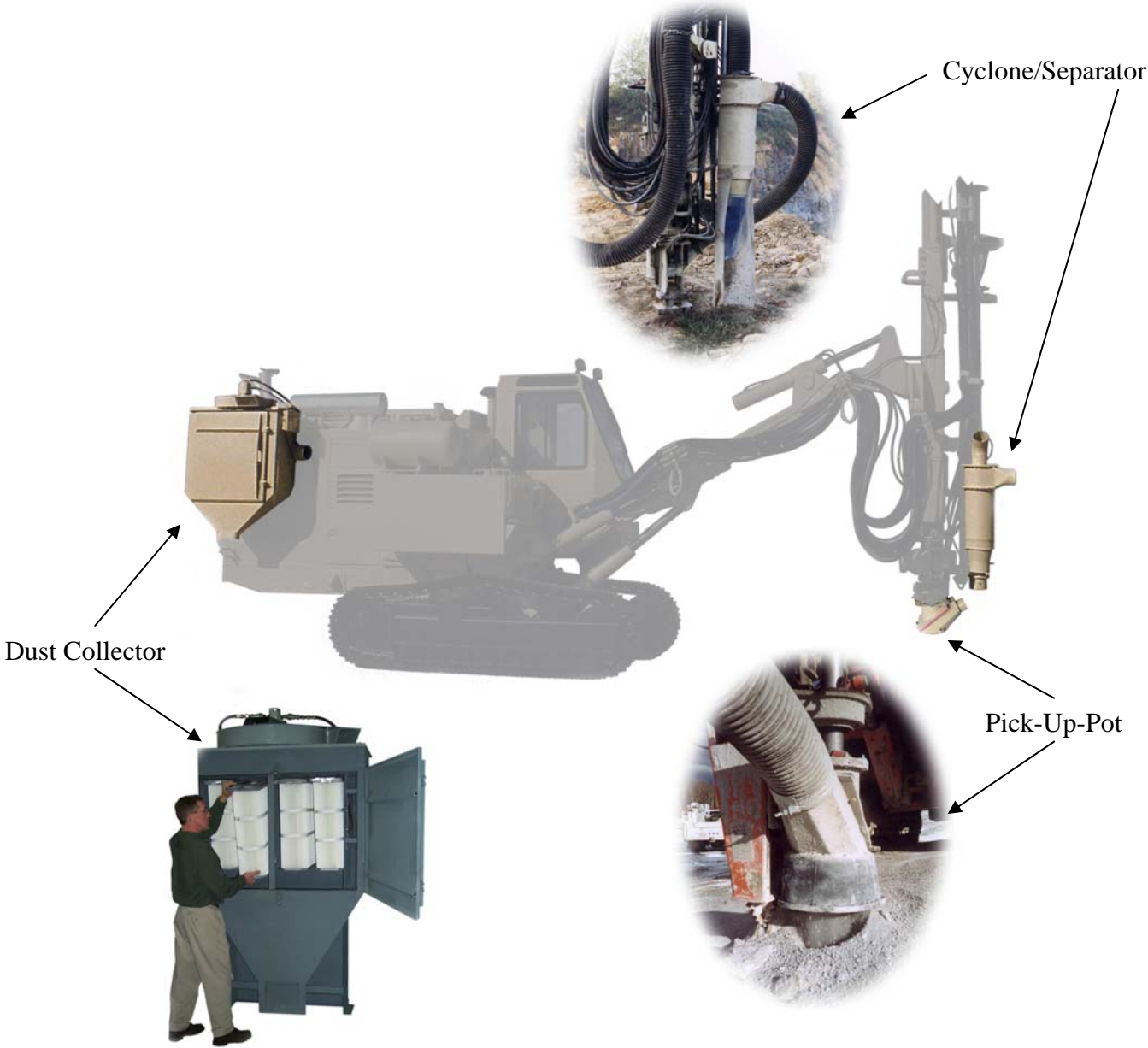

PICK-UP-POT

The Pick-Up-Pot is the first area the dust laden air enters. The dirty air is forced up the drill hole with the drill air following the drill steel. The wiping seals are designed to stop or disrupt the momentum of the air. **The Pick-Up-Pot is designed to be positioned one (1) to two (2) inches above the drilling surface.** This position is important to provide the required fresh air mix and create a sweeping action around the hole. Approximately two parts fresh air mixes with the one part of down-hole air to attain the proper mix to make the system function correctly.

Performance Considerations

- Worn gaskets/skirts must be replaced as needed to maintain good suction at the hole.
 - !! Do not bring the bit up through the gaskets as it will wear the gasket prematurely.
- All gaskets should be sized to the drill rod diameter (see gasket sizing chart page 4).
- Bit to steel ratio will affect up hole velocity and should be considered to reduce up-hole air velocity and minimize leakage around the drill steel.
- The optional angle drilling attachment should be used when angle drilling.
 - The skirt attachment is angled to allow drilling at an angle while maintaining the proper relationship of the pick-up-pot to the ground surface around the hole.

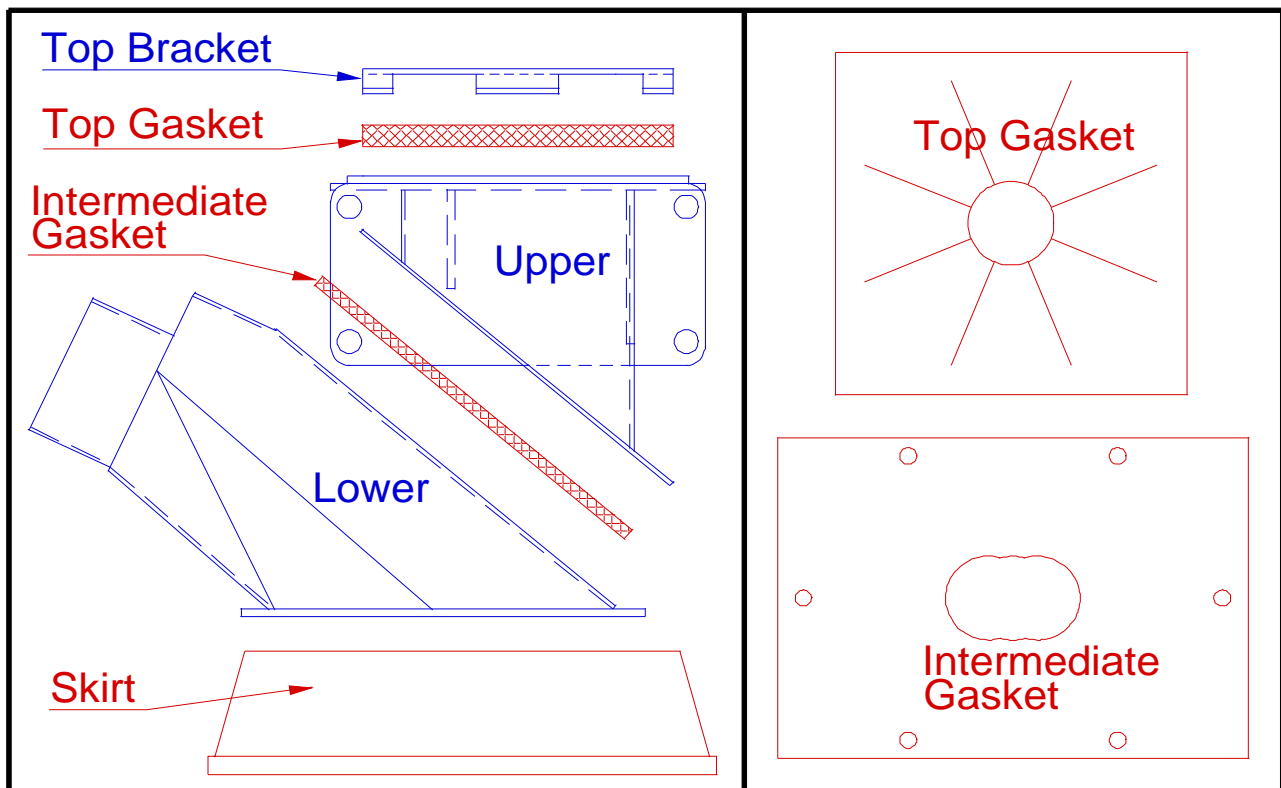

Pick-Up-Pot (PUP) Gasket Sizing Chart

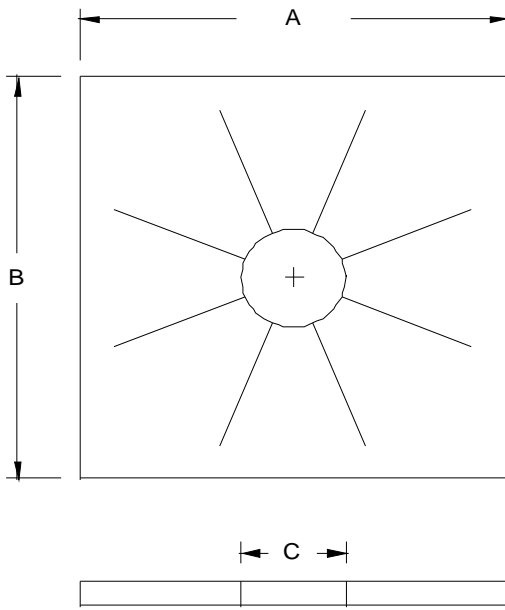

Top Gasket - Pick-Up-Pot

QMP #	inch		
	A	B	C
6GSKT2	9 7/8	9 7/8	2
6GSKT3	9 7/8	9 7/8	3
6GSKT3.5	9 7/8	9 7/8	3.5
6GSKT4	9 7/8	9 7/8	4
8GSKT3.5	11 3/4	11 3/4	3.5
8GSKT4	11 3/4	11 3/4	4

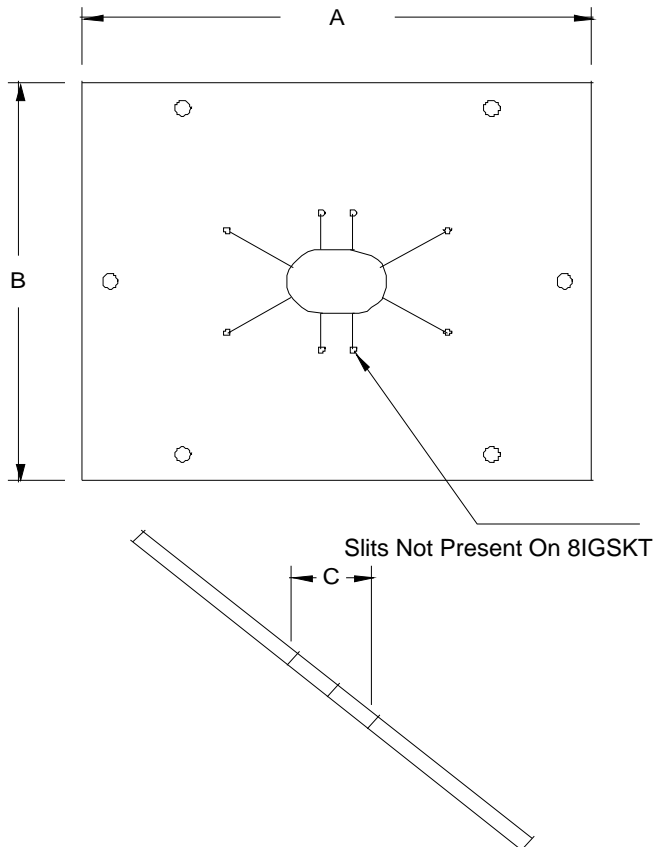

Intermediate Gasket - Pick-Up-Pot

QMP #	inch		
	A	B	C
IGSKT2	14	11 5/8	2
IGSKT3	14	11 5/8	3
6IGSKT3.5	14	11 5/8	3.5
6IGSKT4	14	11 5/8	4
8IGSKT3.5	15 3/4	11	3.5
8IGSKT4	15 3/4	11	4

CYCLONE/SEPARATOR

The Cyclone/Separator is the second component; it eliminates 65% to 90% of the particles from the suction air. This component is very efficient and relatively maintenance free. Proper air flow and vertical position, ($\pm 15^\circ$ of a vertical position), are important to create the centrifugal forces that separate the dirt from the air. When working properly the dump hose will collapse around the cage and seal to create the vacuum back to the dust collector cabinet. The dump hose will open when the fan stops drawing a vacuum which allows the accumulated dust and solid to fall to the ground. The dump pile should not build high enough to prevent the dump hose from sealing. Adjustments to the height of the cyclone can be made by adjusting the mounting arms and brackets on the drill.

Occasionally the dump hose must be checked so that it is closing and maintaining a seal during the operation. A special high abrasive center section is available for operation in abrasive material. Inlet and outlet hose connection must also be checked occasionally for leakage. The wind screen enables unloading of dirt while minimizing the wind from blowing the discharge dust.

Performance Considerations:

- Check wear pad every 2000 hours minimum: Replace as required by wear.
!! Failure to replace worn pad will result in damage to the body.
- The efficiency of the cyclone is affected by a number of variables: material being drilled, bit condition, feed pressure, etc...

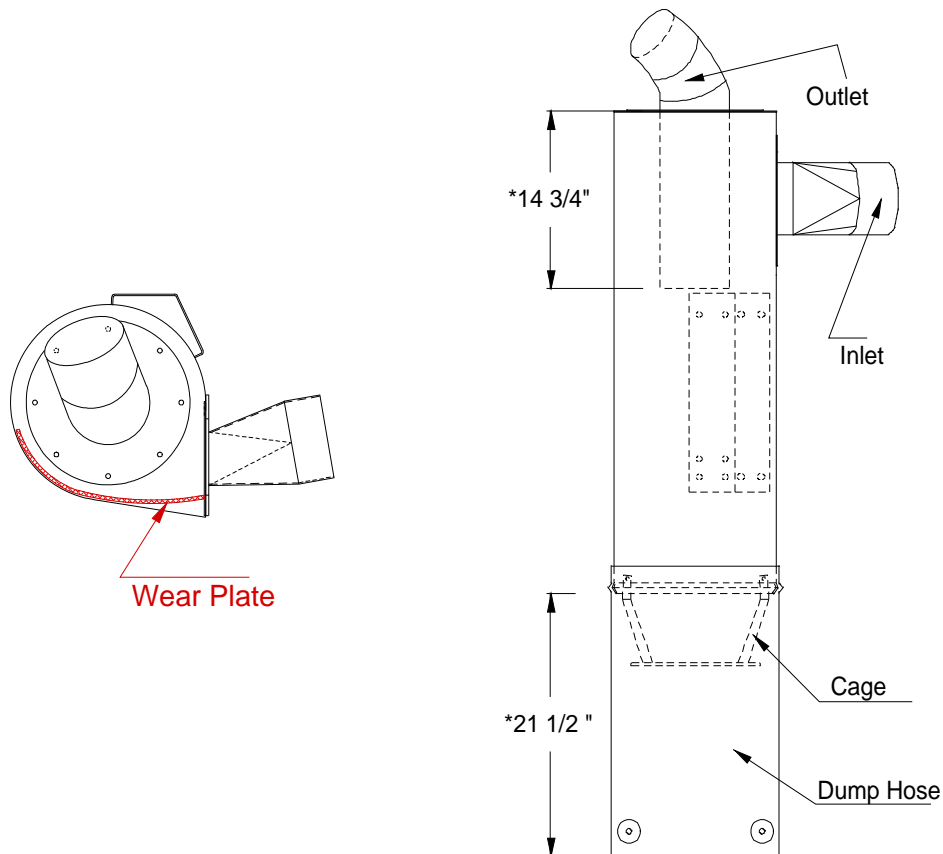

DUST COLLECTION CABINET

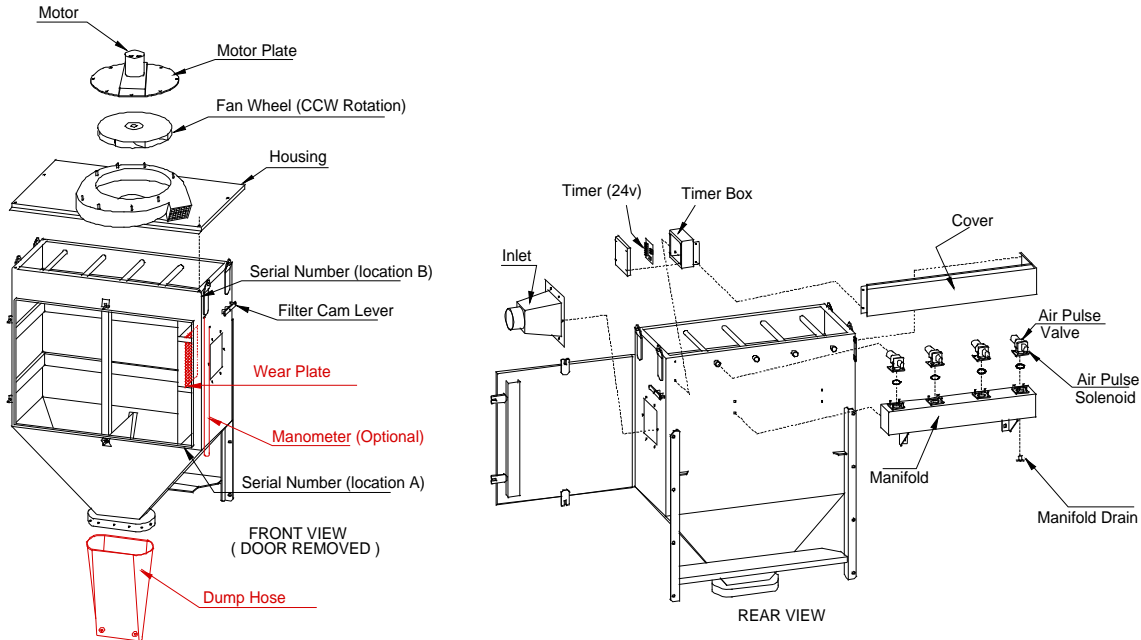

The dust collection cabinet has several components, which are important to the systems operation.

A. Fan Motor:

Your fan motor is a highly efficient fixed displacement gear motor with special bearings designed for fan operation. The hydraulic oil cleanliness is the most important factor in the life of the motor, the filter/oil change requirements for your drill unit must be followed. The exact speed should be set by using a reed or vibration type tachometer; see data sheet for specific model settings. Once these settings are achieved, they can be translated to a water column reading on the manometer. It should be noted that manometer readings are for quick field reference primarily to check the filter condition. Manometer readings should be taken and recorded at start up.

The fan motor is secured with (6) 1/2"-13 x 1 1/2" bolts tightened to a torque of 75-ft.lbs. Use Locktite 242 on the bolt threads: The bolts MUST be checked at delivery, at the first 40 hours of usage, and every 3 months thereafter. The mating surface between the motor and motor plate must be clean; dirt, oil and paint free to ensure correct seating.

B. Fan Wheel:

Your fan wheel has been designed specifically for use with this dust collector. Fan mounting is accomplished with a single 1/2"-20 bolt and Belleville spring washer tightened to a torque of 40-ft.lbs. This bolt MUST be checked at the first 40 hours of operation and every 3 months thereafter.

Each fan wheel is precision balanced at the factory. If the wheel is damaged, altered, or if foreign material accumulates on the blades, the balance will be affected and vibration will result. Accumulation of dust on the fan blades will cause out of balance conditions to develop: **Excessive fan vibration will cause shaft seal failures.**

C. Filters:

Filter life can be greatly extended through proper routine maintenance. **A filter can be ruined by operating under wet conditions.** If water is encountered, the unit should be shut-off and the filters removed and allowed to dry. A worn filter will allow dust to by-pass into the clean air section of the collector. If dust is observed in the fan discharge air the unit should be shut-off and the filters changed so that the fan wheel is not damaged. Filter replacement must include cleaning the gasket seat area and tightening to the point of compressing the gasket to approximately 5/16" thick (between top of filter and collector header plate).

Pulse Cleaning During Operation:

The system is designed to back pulse air through the filters during operation. It is imperative that the filters have a chance to clean themselves during rod or position changes. During a change, the fan should be shut off, either automatically or manually (depending on your drill model) so that dust can be released from the filters via the back pulse cleaning. Failure to turn off the fan will result in poor filter cleaning and loss of suction. (Also See Pneumatics)

Polyester Media Filters, Manual Cleaning Procedures:

The PTFE membrane polyester filter is a very high quality product and care must be taken to insure performance and filter life. The HO polyester media filter is impregnated with a dirt releasing agent and can be removed with improper handling and cleaning. Following these procedures will maximize the life and performance of the product.

- Pulse filters without fan running for 15-30 minutes.
- To remove filters, release filter cam lever on outside of cabinet and front retaining bolts.
- Inspect for damage or wear, be sure to check seal on top of filter. Do not re-use damaged elements
- Vacuum or gently brush off cartridge to remove any excess powder if possible.
- Using compressed air (50 psi max) blow loose dust from the filter from inside out to prevent forcing dust into the pores of the media. Do not use compressed air on the outside surface.
- Using a standard garden hose, gently spray the filter from the inside out.
- Mild dishwashing detergent can be used if desired. This must be thoroughly rinsed.
- Drain water from filter by inverting in all directions.
- Let filters air dry, typically in normal conditions, for minimum of 72 hours before re-use.



CAUTION: DO NOT USE HIGH-PRESSURE OR HIGH TEMPERATURE (above 120° F) WATER SPRAYERS ON THESE FILTERS AS REMOVAL OF THE DIRT RELEASING AGENT(S) MAY OCCUR.

D. Electronic Timer:

Your timer is protected in a covered timer box to protect it from dust, water and other environmental damage. The timer provides timed sequential control for the impulse air cleaning valves. The input voltage is protected with an in-line 3 amp fuse. Additionally you should fuse the electric supply line as close to the battery as possible to protect these wires if cut or shorted.

The "On Time" setting is the duration of the pulse jet for the cleaning air, this is factory set at 0.1 to 0.2 seconds. The "Off Time" is the time between pulses, this should be set for 5 seconds depending on the load of dirt on the filter. L.E.D. indicating lights are provided to visually check power-on and voltage at each station.

!! The timer is factory set and should not be adjusted.

The timer board is isolated from the cabinet, however WELDING anywhere on the drill can feed voltage thru the negative connection to the board and damage the electronic timer. If welding, the + and - connection to the board must be disconnected.

The electrical connection must be free of voltage spikes. Connection is highly recommended to the negative terminal of the battery and the positive just after the ignition switch. The wire must be routed so that it does not pass near solenoid feeds since these cause spikes in the system.

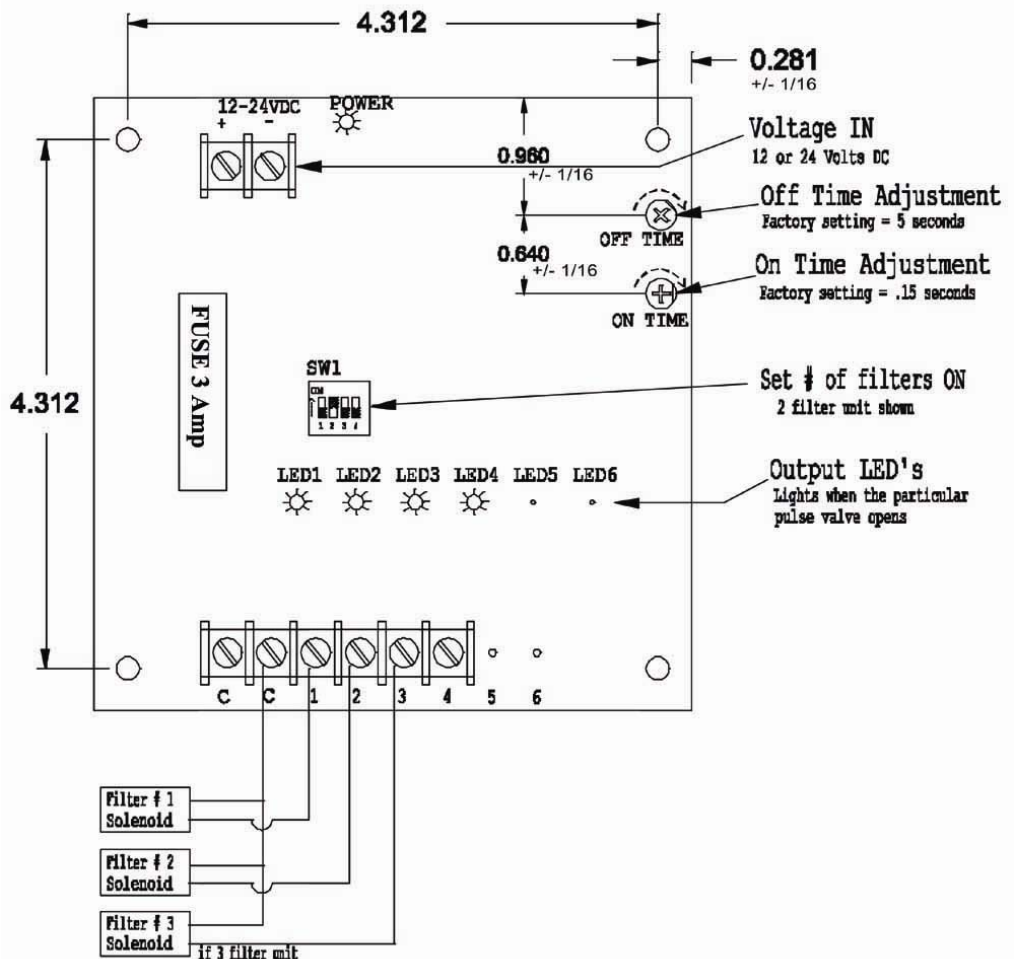

E. Pneumatics:

i. Air Filter Regulator:

An air regulator must be purchased separately and sized appropriately to your compressor and drained daily. A 70 psi pressure relief valve must be installed in the regulator, which is 10 psi above the maximum recommended. Water or oil in your regulator, manifold or air valves can damage these components causing failure of the cleaning system. Further, moisture in the air will increase the accumulation of dust on the fan blades causing out of balance conditions to develop: **Excessive fan vibration will cause shaft seal failures**. The pulse pressure should be set between 40 to 60 psi depending on the type of media and frequency allowing pulsing to purge the media. The higher pressure will shorten the filter life. Air connection should be made with a 3/8" air hose line which acts as a flow limiter should a component will become broken.

ii. Manifold Drain:

The manifold is equipped with a daily drain petcock. Leave this slightly opened during high humidity or high moisture conditions in the compressed air system. Your unit should never be set to exceed 60 psi. This can damage the pneumatic components causing failure.

iii. Impulse Air Valve:

Your unit utilizes reverse jet impulse valves for the filter cleaning process. These valves are controlled by a pressurized port on top of the valve. When depressurized, the valve opens to allow the compressed air in the manifold to quickly vent into the filter element. Occasionally, there is contamination under the seal of the valve allowing the valve to be continuously open; this would have to be cleaned. The valve is an open and free flowing construction, especially designed for impulse cleaning of dust collectors.

iv. Solenoid Valve:

This valve accepts the timer signal and actuates the impulse valve by venting the pressurized control tubing. Tight electrical and pneumatic hose fittings are essential towards its reliable usage. The lower valve portion of this is enclosed in the lower portion of the electrical panel to shield it from the elements and retain some heat to keep water particles from freezing during cold weather operation. The exhaust port is vented out the bottom of the electrical box so that an operator can feel the venting to check the valve operation.

!! Periodically check to make sure each solenoid is firing.

F. Manometer:

Your unit is equipped with ports to accept a manometer which is used to determine three important set-up values. These are not supplied as standard equipment but are available for purchase as a kit from your authorized dealer. All units' ship with a factory preset to the correct vacuum levels: Adjustments to this system should only be made by a qualified service technician. Please refer to Operation & Settings for information specific to your model.

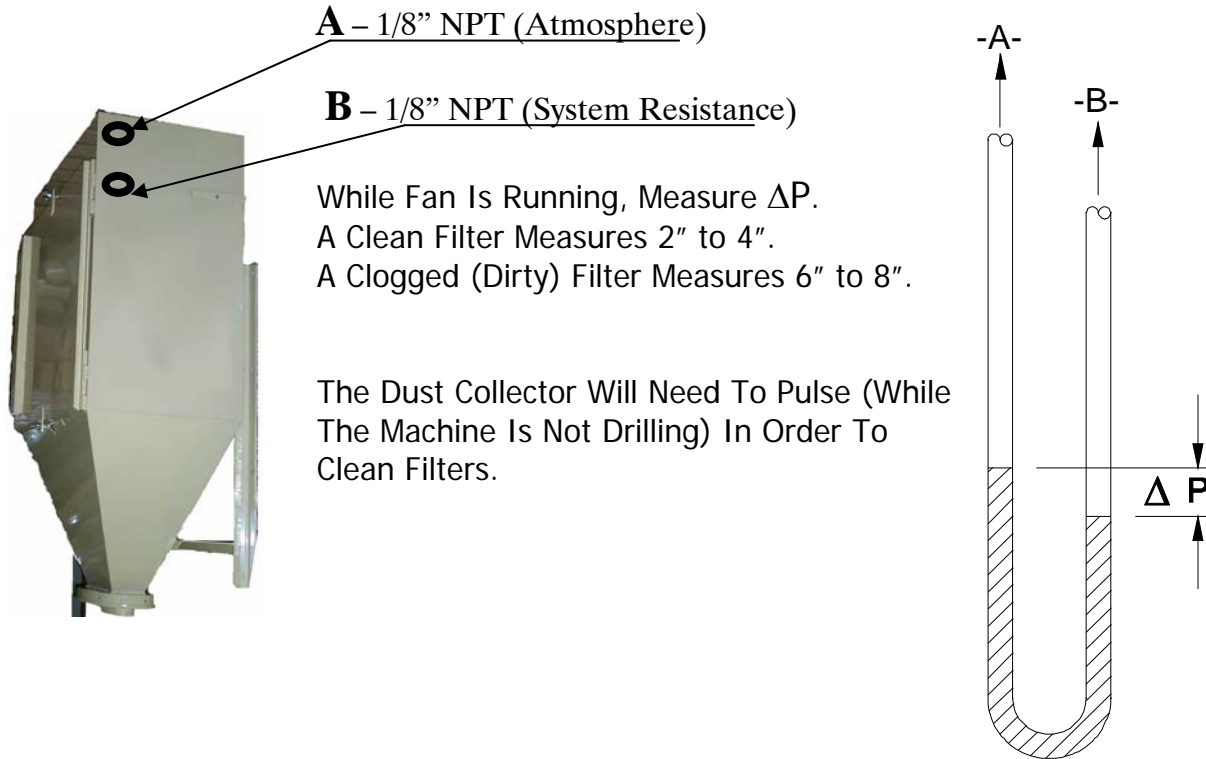

G. Hoses:

The hoses supplied by the manufacturer of the equipment are a critical part of the dust collector system. A small hole in a hose may cause significant loss of suction at the hole due to the pressure loss. It is important that hoses do not have splices, cuts, cracks or other blockage or leakage. Clamps securing the hose to each part of the dust collector system must be secured and tightened to prevent leakage.

Wet discharge from the drill-hole, extreme penetration rates, and drilling in soft overburden are all factors that can cause accumulations in the hose, especially between the pick-up-pot and cyclone.

When possible the hose should be maintained at the shortest length possible to allow complete functions of the machines intended use and to minimize places in the hose which attract accumulations or increase chance of damage to the hose.

TROUBLESHOOTING

Routine inspection of door gasket, suction hose, dump hose pick-up-pot seals and other wear items are necessary to ensure that there are no leaks to the system. Oil cleanliness is important to the life of the hydraulic motor. Filters can be ruined by operating under wet conditions.

A. Poor suction at Pick-Up-Pot:

- ✓ Check for clogs in suction hoses.
- ✓ Check to confirm counterclockwise fan direction (as viewed from top of fan).
- ✓ Check fan speed; see operational settings for your model.
- ✓ Check all hoses for tight connections, tears, holes, etc.
 - A very small hole in the system will cause a large loss of suction at the pick-up-pot.
- ✓ Check for dirty or wet filters, clean and/or replace.
 - Routinely the filters should be removed, cleaned out and inspected for tears.
- ✓ Check to ensure pulse cleaning system is functioning properly.
- ✓ Check to ensure the door gaskets and filter gaskets are sealing.

B. Air manifold does not fill to setting of 40 to 60 psi, air is continually bleeding off:

- ✓ Check to ensure air operated pulse valve seat is not stuck open.
 - Clean seat of impurities.
- ✓ Check to see if the rubber diaphragm is torn.
 - Replace valve diaphragm assembly.
- ✓ Check to see if ¼" control hose is leaking by a split, hole or break in line.
 - Connections should be tight to brass fittings on air valve and solenoid valve.
- ✓ Compressed air must be clean and filtered to ensure no contamination of the valve seats.

C. No pulse noticed at all:

- ✓ Check that the power red light diode is on.
- ✓ Check 3 amp power fuse.
- ✓ Check all connections on timer board.
- ✓ Check red light diodes at the individual solenoid; this indicates that power is being supplied to that solenoid.
- ✓ Check wire connections to solenoids.

D. Dust is coming out blower exhaust:

- ✓ Check the door gasket so that a seat is made around the interior "clean air" upper section.
- ✓ Check to insure that the filters are seated squarely, that the gasket is not damaged, and the filter cam lever engaged.
- ✓ Check that the filter gaskets have been tightened to approx. 5/16" from filter plate.
- ✓ Check the filter for wear or tears at the pleats of the filters.
- ✓ Replace filters.

OPERATION & SETTINGS

Routine inspection of door gaskets, suction hose, dump-hoses pick-up-pot seals and other wear items is necessary to ensure that there are no leaks to the system. Oil cleanliness is important to the life of the hydraulic motor. Compressed Air must be clean and filtered to ensure that there is no contamination of the valve seats. Filters can be ruined by operating under wet conditions. Occasionally the filters can be removed, blown out and inspected for tears.

Consult machine manufacturer's operator manual and schematics for each machine model to insure proper settings.

QMP Dust Collector Technical Data						
Dust collector model #	125	1203*	250	430	530 & 2503*	800
Drills (customer model)		490 / 590	490 / 590	720/760,765	780,785	
Down Hole Air (CFM)			250	480/635	862	
Hole Diameter (Max)	3.5"	4"	5 "	6"	6.5"	8"
Max. Penetration Rate (ft / min)	4.9	3	4.9	4.9	3.5	3.5
Suction Hose Diameter	4" or 5"	5"	4" or 5"	5" or 6"	8"	6" or 8"
Motor Size (cc / cipr)	9 / 0.55	9 / 0.55	9 / 0.55	14 / 0.86	14 / 0.86	17 / 1.04
Fan Model		19TB39	21FF95	26FF150	29FF168	29FF168
Fan Motor Oil Flow (GPM)	6 -8 gpm	6-8 gpm	6-8 gpm	8-10 gpm	11-14 gpm	12-14 gpm
Fan Operating Range (RPM)	2800 - 3000	3400-3500	3350-3400	3100-3200	2850-3150	3000-3300
Fan motor, Working Pressure Max (psi)	3200	3200	3200	3200	3200	3200
Fan Speed (RPM _{Max})	3200	3600	3500	3500	3500	3600
Case Drain Pressure, Max (psi)**			125	125	125	125
Suction Capacity (CFM _{Max})	900	1100	1200	3000	3600	4000
Air Vacuum (Inches Water Column - H ₂ O _{Max})	15	18	24	38	42	45
Number of Filters	1	2	2	3	4	4
Filter Area, ft ²	100	110	200	300	400	550
Cleaning Air Pressure (psi)	55 - 60	55 - 60	55 - 60	55 - 60	55 - 60	55 - 60
Air Req'd @ 55psi (CFM)/ Manifold Vol. (ft ³)		7 / 0.32	7 / 0.32	10 / 0.466	14 / 0.686	14 / 0.686
Voltage For Filter Cleaning (DC volts)	12 or 24	12 or 24	12 or 24	12 or 24	12 or 24	12 or 24
Unit Weight, Clean Filters (lbs)	420	410	510	610	750	830
Pick-Up-Pot Used	PUP4EC	PUP5EC	PUP 5EC	PUP6EC / PUP6DEF	PUP8DEF	PUP6 OR 8
Part Number (Atlas Copco)	N/A	57803934	57803934	57803975 / 52296704	52331089	N/A
Pre- Cleaner / Cyclone Used	1444CYBOD	1455CYBOD	14CYBOD55X	14CYBOD55X	1688CYBOD	1688CYBOD
Part Number (Atlas Copco)	N/A	57703779	57803892	57803926	52329645	52329645

* Out of production

** Case drain must be run directly to tank

QMP DUST COLLECTING SYSTEMS LIMITED WARRANTY

The **DUST COLLECTING SYSTEM** is warranted for one year or 2000 hours of operation from date of installation or 18 months from date of shipment from QMP, whichever occurs first.

Subject to the conditions hereinafter set forth. The manufacturer will repair or replace to the original consumer any portion of the product which proves to be defective due to defective materials or workmanship.

The **CYCLONE/SEPARATOR** is warranted for six months from date of shipment under normal operating conditions.

!! Highly abrasive conditions require a special center section of high strength low alloy steel.

Items NOT covered under this warranty:

- (a) Defects or malfunctions resulting from failure to properly install, operate, or maintain the unit in accordance with the printed instructions provided.
- (b) Failures resulting from abuse, accident or negligence.
- (c) Normal maintenance services and the parts used in connection with such service.
- (d) Normal replacement components or parts.
- (e) Units which are not installed in accordance with applicable local codes, ordinances and good trade practices.
- (f) Unit is used for purposes other than for what it was designed and manufactured.
- (g) Wear Items: filters, pick-up-pot seals, rubber/plastic components, electric timer boards.

The manufacturer reserves the right to determine whether to repair or replace the defective equipment, parts or components. Damage due to conditions beyond the control of the manufacturer will not be covered.

Return of Warranty Components

Contact the dealer from whom the product was purchased to obtain warranty service. Prior to returning any item, authorization must be obtained and a return goods authorization (RGA) number issued. Documentation including: serial numbers (see page 5 for locations), purchase date, and a description of the defect or failure must be provided at this time in order to obtain the RGA.

Any item to be replaced or repaired under this warranty must be returned, freight prepaid, to the manufacturer along with corresponding documentation.

QMP CORPORATION
10040 Cilley Road
Clevel, Ohio 45002